



Address:- Sector 130, Shastri Garhi Shahpur, Noida,  
Uttar Pradesh- 201304  
Mob:- +91 - 981187005, 9711966037, 9711966066  
Email:- seereba@seereba.com, sales@seereba.com  
Website:- www.seereba.com

Your Global Automation Partner

**TURCK**

# Ri-QR24 Contactless Encoder



# Inductive Encoder Eliminates Need for Compromises



Turck's new encoder means that the user no longer has to make a compromise between resolution and rugged design. All the measures required to protect encoders from mechanical stress using springs or double bearings are no longer necessary. Apart from the interference immunity and wear-free design of the system, the user also benefits from the universal parametrization concept.

The mounting concept also keeps this universal approach: Adapter rings make it possible for the user to fit the positioning element to shafts of different diameters. He only has to keep a single encoder in stock which he can use for all applications on shafts up to 20 mm in diameter. Our customers are thus able to reduce their storage costs effectively.

The QR24 universal encoder can be used for a countless number of applications and replace several 100 different encoder types.

The resonant circuit measuring principle makes it possible to design a fully potted sensor housing without seals, that is separate from the positioning element. This therefore fully excludes the possibility of dust or water penetrating into the electronics.

The contactless measuring principle of the encoder enables it to compensate for vibration and offset.

Magnetic fields cannot disturb the measuring process, since the positioning element is not based on a magnet but on an inductive coil system, through which the sensor and the positioning element (resonator) can form an oscillation circuit.

# Table of Contents



**Address:-** Sector 130, Shastri Garhi Shahpur, Noida, Uttar Pradesh- 201304  
**Mob:-** +91 - 981187005, 9711966037, 9711966066  
**Email:-** seereba@seereba.com, sales@seereba.com  
**Website:-** www.seereba.com

## QR24 inductive encoders

Technology	4
Features	6
Customer benefits	8

## Standard variants – types and data

Absolute singleturn/multiturnencoderwithSSI interface	Absolute single-turn encoder	10
with settable analog output (U/I)	Absolute single-turn encoder with settable analog output (U), for mobile machines	12
	Absolute single-turn encoder with settable IO-Link output	14
Incremental encoder – Push pull with A, B, A, B and Z track	Absolute single-turn encoder with CANopen interface	16
	– –	18
		20

## Stainless steel variants – types and data

Stainless steelinductiveencoder – EQR24 for theharshhest environments	22
Absolute single/multiturn encoder with SSI interface with stainless steel housing	24
Incremental encoder – Push pull with A, B, A, B and Z track with stainless steel housing	26

## Accessories

Accessories for fieldbus connections	28
Connection and functional accessories	30
Ready-to-install positioning element	31
Positioning element and reducing bushings	32
Shield plates/standard mounting accessories	33
Mounting types	34

## The Technology – Precise, Rugged and Safe

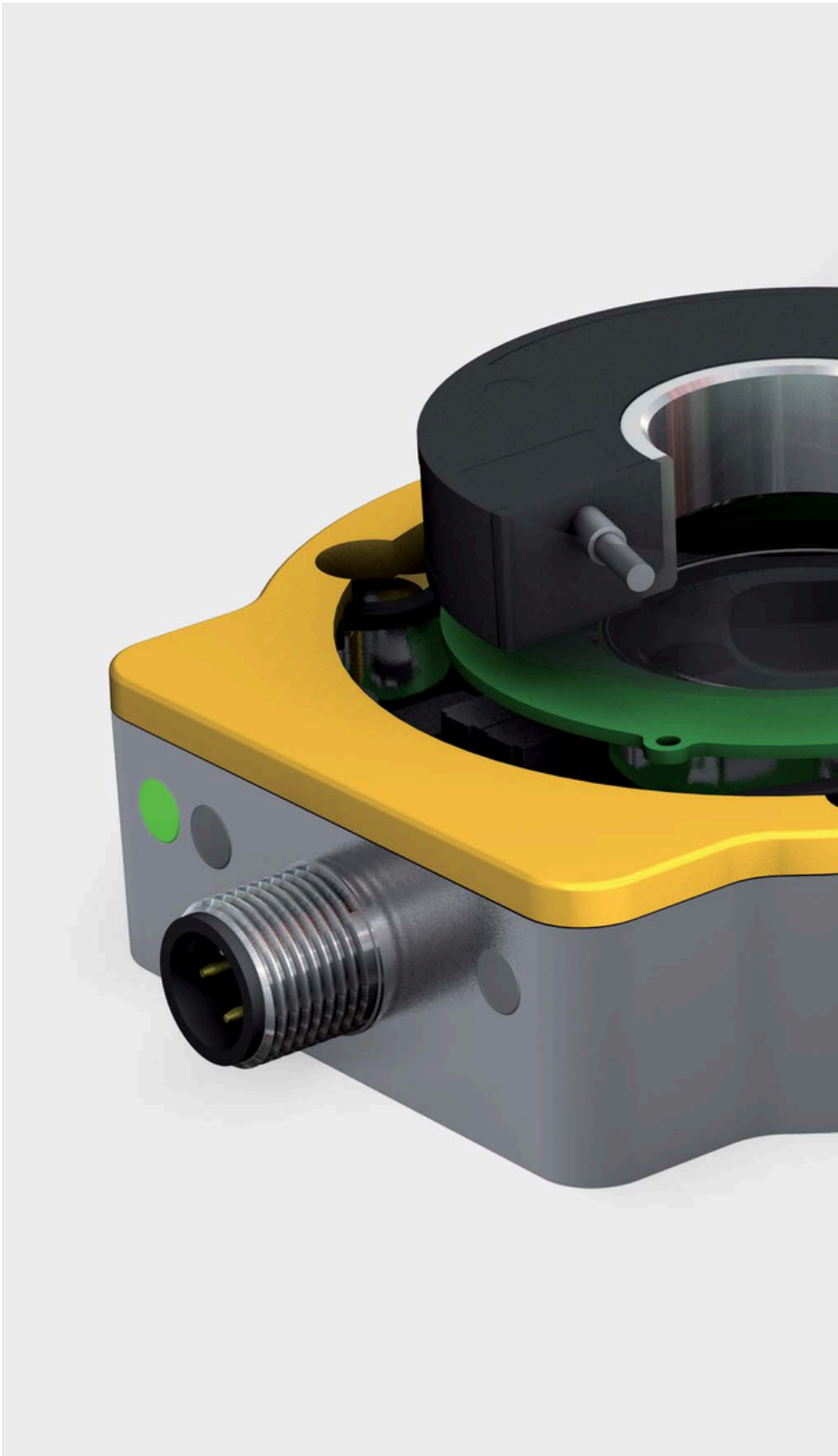

### Measuring principle

The measuring principle of the new encoders is based on the revolutionary, inductive resonance coupling circuit, which offers considerable benefits compared to optical or magnetic measuring principles. The sensor houses emitter and receiver coil systems that are manufactured as printed circuit coils with exceptional precision. The emitter coils are excited with a high-frequency AC field and form with the positioning element, the so-called resonator, an inductive resonance coupling circuit. This causes the positioning element to be inductively coupled with the receiver coils. The geometry of the receiver coils is designed so that different voltages are induced in the coils depending on the position of the positioning element, and thus determine the sensor signal supplied. The sensor is provided with a low-precision and a high-precision receiver coil system in order to increase its flexibility and measuring speed. The low-precision receiver coil system locates the positioning element firstly with less accuracy, whilst the high-precision system carries out the fine position measuring.

### Electronics and coil geometry

A special coil arrangement ensures that stable resonance coupling is implemented in a defined distance range, and that the sensor signal does not change if there is any lateral movement or a change in distance.

The signals are evaluated in the internal 32-bit processor and are presented at the output with an exceptionally high resolution. The electronics are implemented on two board levels. The PCB on which the sensor element is positioned is located directly under the active face; the electronic circuit for the signal evaluation on the other hand, is housed one level below it.

### Status LEDs

The encoder independently monitors its operational readiness and indicates this with a green LED. It warns the user of any impending signal loss between the sensor and positioning element via the yellow LED. Faults are indicated via the red LED. The operational status of the sensor is thus easily determined at any time.

### Housing and shaft adaption

The housing of the inductive encoder is made of metal, with plastic on the active face. The sensor can be mounted easily from both sides. The positioning element is adapted to the shaft in place by means of a shaft ring supplied. This is available in various diameters from 6 to 20 mm, and 1/8" and 3/8". The positioning element can also be screwed frontally to the shaft and then covered with the supplied blinding plug.



# Features

## Contactless rotation measuring

The new measuring process is a completely contactless and wear-free system. Important characteristics such as accuracy, linearity and sealing are thus retained for the entire lifespan of the sensor and guarantee perfect sensor operation at any time.



## Rugged and fully sealed housing

The fully potted die-cast metal housing ensures the high mechanical strength of the sensor. The sensor is moreover perfectly resistant to many chemicals and oils. The metal housing is rugged and can be mounted in many different ways.

Combined with the comprehensive range of mounting accessories, the sensor can always be mounted in the installation securely, flexibly and simply. Turck inductive encoders come in highly sealed housings and offer permanent protection to IP67/IP69K. The devices are also resistant to a number of aggressive ambient media.

## Mechanically and electrically wear-free

The major disadvantage of previous encoders is the necessary direct mechanical connection of the rotating shaft that is inherent in their design. The seal of the encoder housing also becomes brittle, cracked and then leaks due to the stress permanently induced by the slightly rotating shafts. Penetrating water, dust or emulsions damage the sensitive sensor circuit and cause downtimes. This may lead to a failure of the sensor and finally to the total and unplanned downtime.

The QR24 inductive encoder works without any mechanical coupling into the fully potted sensor housing. This contactless encoder is therefore not only electrically but also mechanically wear-free.





**Address:-** Sector 130, Shastri Garhi Shahpur, Noida, Uttar Pradesh- 201304  
**Mob:-** +91 - 981187005, 9711966037, 9711966066  
**Email:-** seereba@seereba.com, sales@seereba.com  
**Website:-** www.seereba.com

**Flexible accessories, teachability**

Every application is different: The mechanical components involved, such as the shaft diameter, may be different. The electrical system may require a single turn or a multiturn signal.

Thanks to its ingenious mechanical concept, the Turck inductive encoder can be adapted perfectly to any standard shaft by means of different reducing bushings. The QR 24 encoder series consists of teachable sensors that customers can also adapt electrically in no time to the requirements of the application at hand.

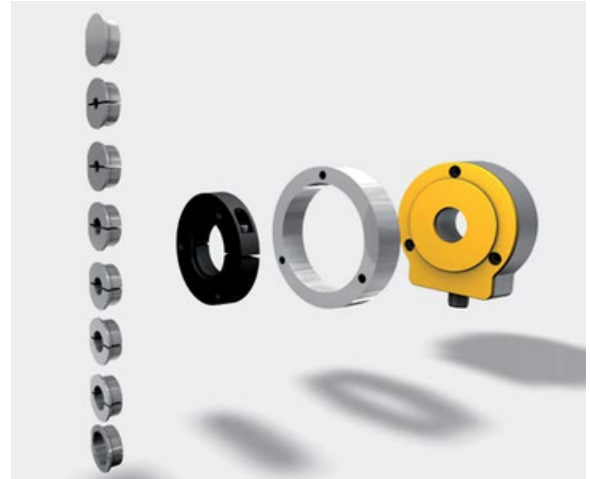

**Many different interface signals**

Various output types, such as an analog current or voltage output, incremental or SSI output, make it possible to carry out the required adaption to the higher-level PLC. The signal can also be connected via the Turck I/O systems to different bus systems for example. The connection is always established with M12 x 1 standard male connectors so that any special connectors are unnecessary. Unnecessary expenses for connection are avoided.

**Highest accuracy and interference immunity**

The measuring principle and the system resolution of the new inductive encoders ensure highly precise measuring signals and thus enable a very high linearity and reproducibility. The encoder operates with a resonator oscillation circuit and is therefore immune to any kind of magnetic field whilst offering an outstanding EMC performance. Mechanical interference is also not a problem as this system operates without a shaft fitted in the sensor unit. Environmental factors such as water, dust or vibration on the shaft that could considerably wear the mechanical components or destroy the electrical circuitry are thus irrelevant.



## Customer benefits



### Process safety

The encoder offers reliable operation at any time even in the harshest ambient conditions. The sensor comes with protection to IP67/IP69K and constantly supplies precise results, even if it is exposed to dust or water. Vibrations and any horizontal or vertical movement of the positioning element do not affect the output signal. The encoder is not affected by magnetic fields (such as caused by electric motors) since the resonant circuit measuring principle provides the sensor with an outstanding EMC performance. Logically implemented state-of-the-art technology has thus been used to ensure fewer downtimes during production.

### Flexibility

As a system supplier, Turck not only offers the sensors but also the appropriate connection to higher-level systems. The inductive encoders offer a wide range of interface types, and allow connection to standard fieldbus systems (e.g. to the Turck fieldbus systems BL20, BL67, piconet® and BL compact). The range of shaft adapters on offer is also flexible in order to support the different mounting options possible.



**Address:-** Sector 130, Shastri Garhi Shahpur, Noida,  
Uttar Pradesh- 201304  
**Mob:-** +91 - 981187005, 9711966037, 9711966066  
**Email:-** seereba@seereba.com, sales@seereba.com  
**Website:-** www.seereba.com



### Standardization

The simple and flexible parametrization enables the sensor to be adapted to the particular requirements of the user, for example, with regard to the SSI bit length and the measuring range for an analog voltage interface. The available shaft adapters (reducing bushings) make it possible to use the existing shaft in place and for all standard diameters.

The standardization thus makes it possible to achieve a high level of stock availability. Turck can respond to new requirements within a few days, thus enabling the customer to keep his stock to a minimum. Turck offers this delivery service worldwide through a large number of subsidiaries and agencies. Customers worldwide can therefore benefit from Turck's manufacturing expertise.

### Maintenance free

Unlike conventional optical encoders that fail with time due to the inherent permanent stress on the shaft bearings, the new inductive encoder also operates mechanically contact-free, i.e. wear-free and maintenance-free. LEDs indicate any faults and are clearly visible even from a distance. Status queries can also be implemented in this way.

# Encoder Ri-QR24

## Absolutesingle/multiturnencoder with SSI interface

### Product features

- Compact and rugged housing
- Synchronous Serial Interface (SSI) 25-bit, Gray coded ( default ) SSI cycle rate: 62.5 KHz...1 MHz Single turn Bit 0...15, multiturn Bit 16...21, Status bit 22...24 (default) Single or multiturn mode, data frame length as well as bit coding settable via PACTware™ with programming box USB- 2-IOL-0002 and adapter cable
- Male connector, M12 x 1, 8-pin

### LED indication

- green: Sensor power supply OK
- green flashing: Sensor in synchronous operating mode
- green fast flashing: Sensor is supplied properly but is not receiving CLK pulses from the SSI master
- yellow off: Positioning element in measuring range
- yellow on: Positioning element has reached the end of the measuring range. This is indicated by a weaker signal (e.g. distance too large), see status Bit 23

- yellow flashing: Positioning element not in coverage, see status Bit 24

### Multiturn errors

- red: Position changed during a power loss, see status Bit 22

**Ri360P1-QR24M1-HESG25X3-H1181**

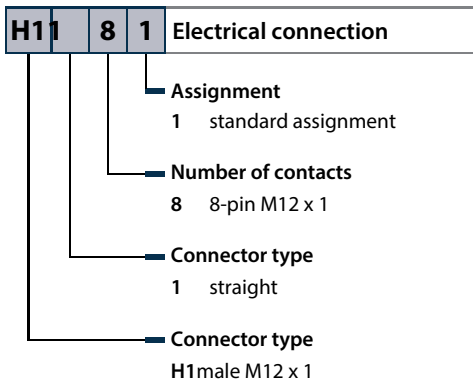
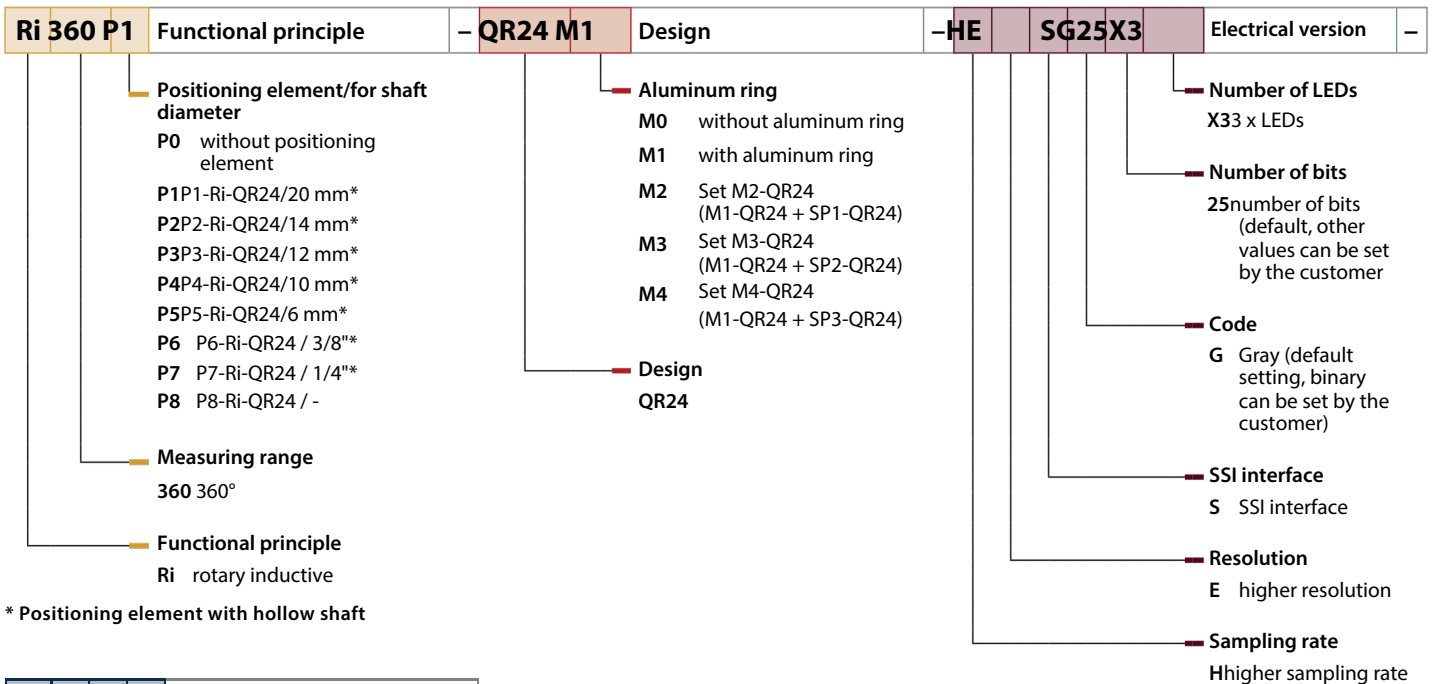

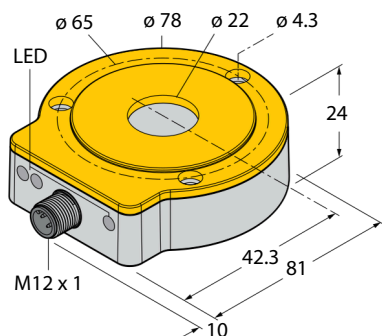

#### Wiring diagram

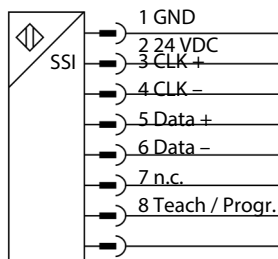

#### Pinout



#### Measuring range details

Measuring range	0...360°
max. rotational speed	single or multiturn mode 6.000 U/min
starting torque, shaft load	determined with standardized construction, with a steel shaft $\varnothing$ 20 mm, L = 50 mm and reducer $\varnothing$ 20 mm does not apply, because of contactless measuring principle

#### System

Resolution single turn mode	16 Bit (default)
Resolution multiturn mode	6 Bit (default)
Repeatability	0.01 %
Linearity deviation	$\leq 0.05$ % full scale
Temperature drift	$\leq \pm 0.003$ %/K
Ambient temperature	-25...+85 °C
Nominal distance	1.5 mm

#### Electrical data

Operating voltage	15...30 VDC
Ripple	$\leq 10$ % $U_{ss}$
Rated insulation voltage	$\leq 0.5$ kV
Reverse polarity protection	yes (power supply),
Output function	SSI, 25-bit, Gray coded (SSI acc. to SSI standard RS422)
Process data range	parameterizable
Diagnostic bits	Bit 22: Position changed during a power loss Bit 23: Positioning element has reached the end of the measuring range. This is indicated by a weaker signal. (e.g. distance too large) Bit 24: Positioning element is outside the coverage. Data telegram can be set as multiturn and single turn process data or error bits
Sampling rate	up to 5000 Hz/the sampling rate of the sensor depends on the SSI cycle time of the master.
Current consumption	< 100 mA

#### Housing

Dimensions	81 x 78 x 24 mm
Housing material	metal/plastic, ZnAlCu1/PBT-GF30-V0
Connection	male connector, M12 x 1, 8-pin
Vibration resistance	55 Hz (1 mm)
Vibration resistance (EN 60068-2-6)	20 g, 10...3000 Hz, 50 cycles, 3 axes
Shock resistance (EN 60068-2-27)	100 g, 11ms 1/2 sine, each 3x, 3 axes
Continuous shock resistance (EN 60068-2-29)	40 g, 6 ms 1/2 sine, each 4000x, 3 axes
Protection class	IP68/IP69K
MTTF	138 years acc. to SN 29500 (Ed. 99) 40 °C

#### LED indication

Operating voltage	LED green/LED green flashing synchronous operating mode
Measuring range	LED, yellow, yellow flashing
Error message	LED red

# Encoder Ri-QR24

## Absolute single turn encoder with parameterizable analog interface (U/I)

### Product features



- Compact and rugged housing
- Versatile mounting possibilities
- Immune to electromagnetic interference
- Freely programmable measuring range
- 16-bit resolution
- Operating voltage 15...30 VDC
- Analog output, 0...10 V and 4...20 mA
- Male connector, M12 x 1, 5-pin
- Analog output configurable: e.g. 0...20 mA
- Defined error level at the output

### LED indication



- green: Sensor power supply OK
- yellow off: Positioning element in measuring range
- yellow on: Positioning element has reached the end of the measuring range. This is indicated by a weaker signal. (e.g. distance too large)
- yellow flashing: Positioning element is outside the coverage

Ri 360 P1 - QR24 M1 - ELiU5 X2 - H1 1 5 1

Ri 360 P1	Functional principle	QR24 M1	Design	ELiU5 X2	Electrical version
	<ul style="list-style-type: none"> <li>Positioning element/for shaft diameter               <ul style="list-style-type: none"> <li>P0 without positioning element</li> <li>P1 P1-Ri-QR24/20 mm*</li> <li>P2 P2-Ri-QR24/14 mm*</li> <li>P3 P3-Ri-QR24/12 mm*</li> <li>P4 P4-Ri-QR24/10 mm*</li> <li>P5 P5-Ri-QR24/6 mm*</li> <li>P6 P6-Ri-QR24 / 3/8"*</li> <li>P7 P7-Ri-QR24 / 1/4"*</li> <li>P8 P8-Ri-QR24 / -</li> </ul> </li> <li>Measuring range               <ul style="list-style-type: none"> <li>360 360°</li> </ul> </li> <li>Functional principle               <ul style="list-style-type: none"> <li>Ri rotary inductive</li> </ul> </li> </ul>	<ul style="list-style-type: none"> <li>Mounting aid               <ul style="list-style-type: none"> <li>M0 without aluminum ring</li> <li>M1 with aluminum ring</li> <li>M2 Set M2-QR24 (M1-QR24 + SP1-QR24)</li> <li>M3 Set M3-QR24 (M1-QR24 + SP2-QR24)</li> <li>M4 Set M4-QR24 (M1-QR24 + SP3-QR24)</li> </ul> </li> <li>Design               <ul style="list-style-type: none"> <li>QR24</li> </ul> </li> </ul>	<ul style="list-style-type: none"> <li>Number of LEDs               <ul style="list-style-type: none"> <li>X2 2 x LEDs</li> </ul> </li> <li>Inter face               <ul style="list-style-type: none"> <li>ELiU5 analog output, 4...20 mA and 0...10 V</li> </ul> </li> </ul>		

\* Positioning element with hollow shaft

H11 5 1	Electrical connection
	<ul style="list-style-type: none"> <li>Assignment               <ul style="list-style-type: none"> <li>1 standard assignment</li> </ul> </li> <li>Number of contacts               <ul style="list-style-type: none"> <li>5 5-pin M12 x 1</li> </ul> </li> <li>Connector type               <ul style="list-style-type: none"> <li>1 straight</li> </ul> </li> <li>Connector type               <ul style="list-style-type: none"> <li>H1 male M12 x 1</li> </ul> </li> </ul>

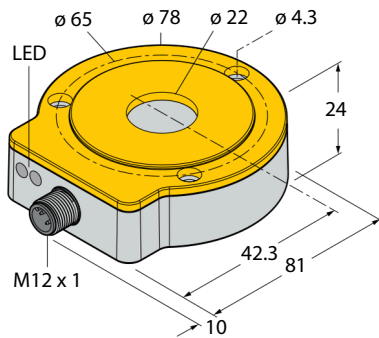

#### Wiring diagram

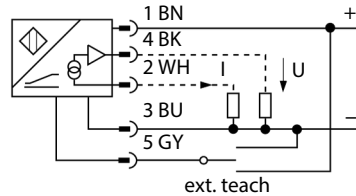

#### Pinout



#### Measuring range details

Measuring range	0...360°
max. rotational speed	single turn mode 12.000 U/min determined with standardized construction, with a steel shaft $\varnothing$ 20 mm, L = 50 mm and reducer $\varnothing$ 20 mm
starting torque, shaft load	does not apply, because of contactless measuring principle

#### System

Resolution	16-bit
Repeatability	0.01 %
Linearity deviation	$\leq 0.05$ % full scale
Temperature drift	$\leq \pm 0.004$ %/K
Ambient temperature	-25...+85 °C
Nominal distance	1.5 mm

#### Electrical data

Operating voltage	15...30 VDC
Ripple	$\leq 10$ % $U_{ss}$
Rated insulation voltage	$\leq 0.5$ kV
Reverse polarity protection	yes (power supply)
Output function	analog interface
Voltage output	0...10 V
Current output	4...20 mA
Load resistance voltage output	$\geq 4.7$ k $\Omega$
Load resistance current output	$\geq 0.4$ k $\Omega$
Sampling rate	5000 Hz
Current consumption	< 100 mA

#### Housing

Dimensions	81 x 78 x 24 mm
Housing material	metal/plastic, ZnAlCu1/PBT-GF30-V0
Connection	male connector, M12 x 1, 5-pin
Vibration resistance	55 Hz (1 mm)
Shock resistance (EN 60068-2-6)	20 g, 10...3000 Hz, 50 cycles, 3 axes
Shock resistance (EN 60068-2-27)	100 g, 11ms 1/2 sine, each 3x, 3 axes
Continuous shock resistance (EN 60068-2-29)	40 g, 6 ms 1/2 sine, each 4000x, 3 axes
Protection class	IP68/IP69K
MTTF	138 years acc. to SN 29500 (Ed. 99) 40 °C

#### LED indication

Operating voltage	LED green
Measuring range	LED, yellow, yellow flashing

# Encoder Ri-QR24

Absolute single turn encoder with parameterizable analog interface (U), for mobile machines

## Product features

- Compact and rugged housing
- Versatile mounting possibilities
- Immune to electromagnetic interference
- Programmable measuring range
- 16-bit resolution
- Operating voltage 8...30 VDC
- Analog interface 0.5...4.5 V
- Male connector M12 x 1
- Temperature range -40...85 °C

## LED indication

- green: Sensor power supply OK
- yellow off: Positioning element in measuring range
- yellow on: Positioning element has reached the end of the measuring range. This is indicated by a weaker signal. (e.g. distance too large)
- yellow flashing: Positioning element is outside the coverage

**Ri 360 P1 - QR24 M1 - ELU4 X2 - H1 1 5 1 /S97**

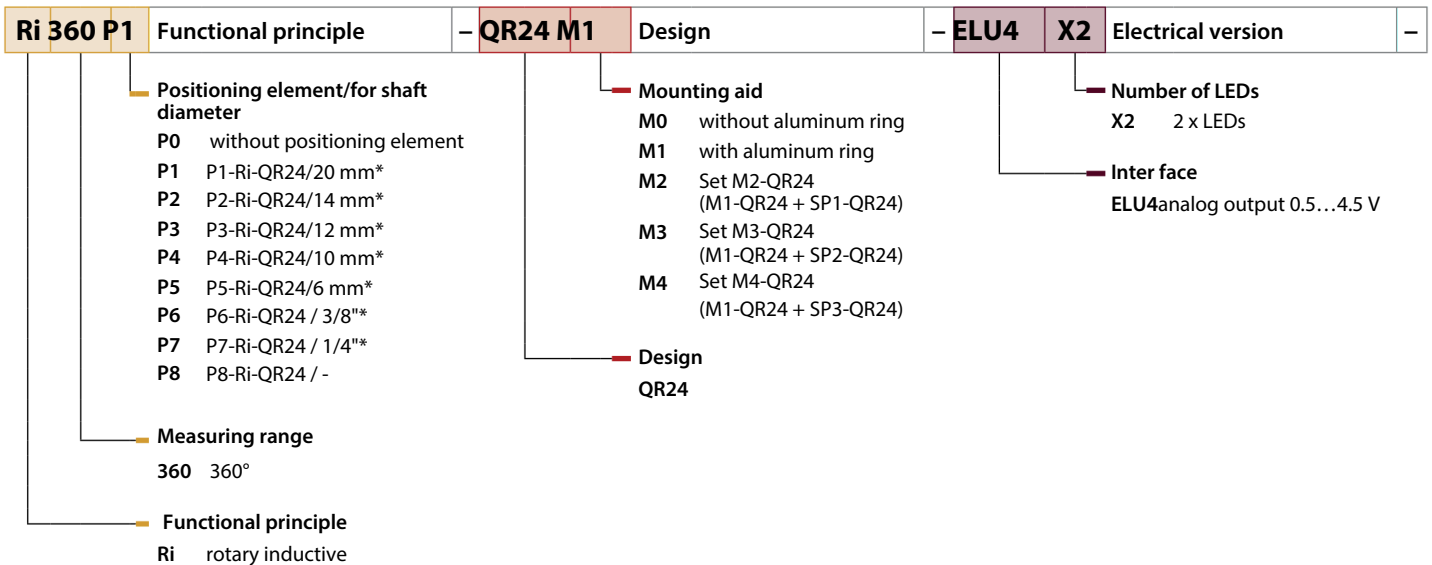

\* Positioning element with hollow shaft

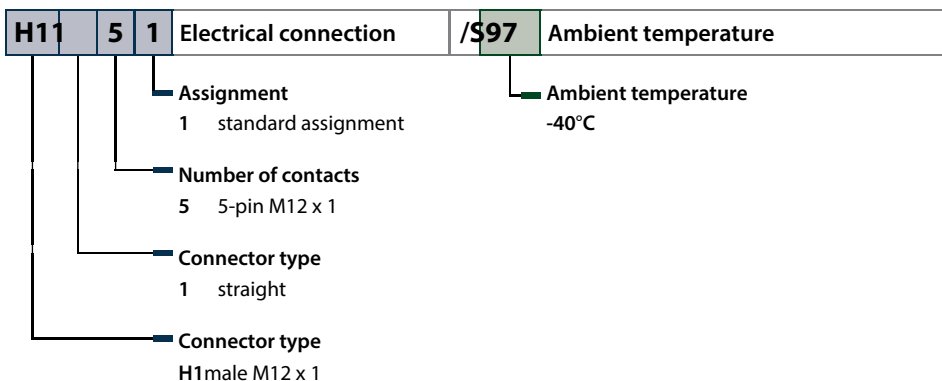

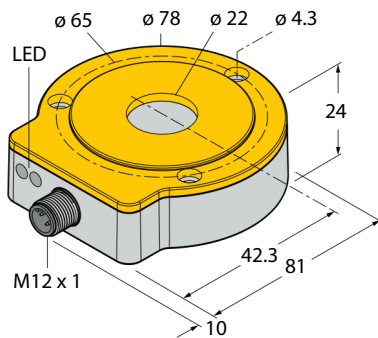

**Wiring diagram**

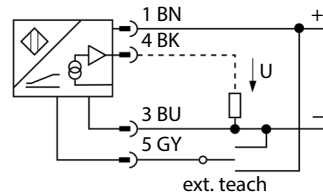

**Pinout**



**Measuring range details**

Measuring range	0...360°
max. rotational speed	single turn mode 12.000 U/min
starting torque, shaft load	determined with standardized construction, with a steel shaft Ø 20 mm, L = 50 mm and reducer Ø 20 mm does not apply, because of contactless measuring principle

**System**

Resolution	16-bit
Repeatability	0.01 %
Linearity deviation	≤ 0.05 % full scale
Temperature drift	≤ ± 0.004 %/K
Ambient temperature	-40 °C...+85 °C
Nominal distance	1.5 mm

**Electrical data**

Operating voltage	8...30 VDC
Ripple	≤ 10 % U <sub>ss</sub>
Rated insulation voltage	≤ 0.5 kV
Reverse polarity protection	yes (power supply)
Output function	analog interface
Voltage output	0.5...4.5 V
Load resistance voltage output	≥ 4.7 kΩ
Sampling rate	5000 Hz
Current consumption	< 100 mA

**Housing**

Dimensions	81 x 78 x 24 mm
Housing material	metal/plastic, ZnAlCu1/PBT-GF30-V0
Connection	male connector, M12 x 1, 4/5-pin
Vibration resistance	55 Hz (1 mm)
Vibration resistance (EN 60068-2-6)	20 g, 10...3000 Hz, 50 cycles, 3 axes
Shock resistance (EN 60068-2-27)	100 g, 11 ms ½ sine, each 3x, 3 axes
Continuous shock resistance (EN 60068-2-29)	40 g, 6 ms ½ sine, each 4000x, 3 axes
Protection class	IP68/IP69K
MTTF	138 years acc. to SN 29500 (Ed. 99) 40 °C

**LED indication**

Operating voltage	LED green
Measuring range	LED, yellow, yellow flashing

# Encoder Ri-QR24

## Absolute single/multiturn Encoder with IO-Link interface

### Product features

- Compact and rugged housing
- Versatile mounting possibilities
- Measuring range programmable, single turn mode
- All functions parameterizable via IO-Link/PACTware™
- Single turn process values in IO-Link telegram
- Male connector, M12 x 1, 4-pin

### LED indications:

- green: Sensor power supply OK
- yellow off: Positioning element in measuring range
- yellow on: Positioning element has reached the end of the measuring range. This is indicated by a weaker signal. (e.g. distance too large)
- yellow flashing: Positioning element is outside the coverage

**Ri 360 P1 - QR24 M1 - IOL X2 - H1 1 4 1**

Ri 360 P1	Functional principle	QR24 M1	Design	IOL X2	Electrical version
	<ul style="list-style-type: none"> <li>Positioning element/for shaft diameter</li> <li>P0 without positioning element</li> <li>P1 P1-Ri-QR24/20 mm*</li> <li>P2 P2-Ri-QR24/14 mm*</li> <li>P3 P3-Ri-QR24/12 mm*</li> <li>P4 P4-Ri-QR24/10 mm*</li> <li>P5 P5-Ri-QR24/6 mm*</li> <li>P6 P6-Ri-QR24 / 3/8"</li> <li>P7 P7-Ri-QR24 / 1/4"</li> <li>P8 P8-Ri-QR24 / -</li> </ul>		<ul style="list-style-type: none"> <li>Mounting aid</li> <li>M0 without aluminum ring</li> <li>M1 with aluminum ring</li> <li>M2 Set M2-QR24 (M1-QR24 + SP1-QR24)</li> <li>M3 Set M3-QR24 (M1-QR24 + SP2-QR24)</li> <li>M4 Set M4-QR24 (M1-QR24 + SP3-QR24)</li> </ul>		<ul style="list-style-type: none"> <li>Number of LEDs</li> <li>X2 2 x LEDs</li> </ul>
	<ul style="list-style-type: none"> <li>Measuring range</li> <li>360 360°</li> </ul>		<ul style="list-style-type: none"> <li>Design</li> <li>QR24</li> </ul>		<ul style="list-style-type: none"> <li>Inter face</li> <li>IOL IO-Link capable</li> </ul>
	<ul style="list-style-type: none"> <li>Functional principle</li> <li>Ri rotary inductive</li> </ul>				

\* Positioning element with hollow shaft

H11	4	1	Electrical connection
			<ul style="list-style-type: none"> <li>Assignment</li> <li>1 standard assignment</li> </ul>
			<ul style="list-style-type: none"> <li>Number of contacts</li> <li>4 4-pin M12 x 1</li> </ul>
			<ul style="list-style-type: none"> <li>Connector type</li> <li>1 straight</li> </ul>
			<ul style="list-style-type: none"> <li>Connector type</li> <li>H1 male M12 x 1</li> </ul>

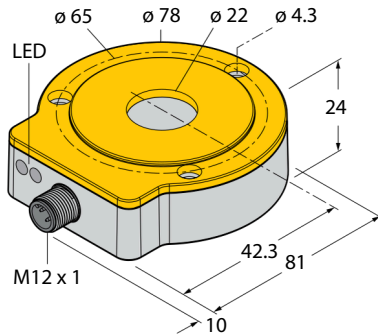

#### Wiring diagram

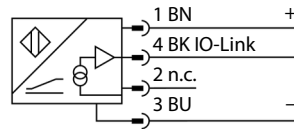

#### Pinout

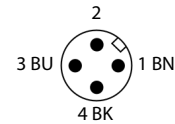

#### Measuring range details

Measuring range	0...360°
starting torque, shaft load	single turn mode does not apply, because of contactless measuring principle

#### System

Resolution	16-bit
Repeatability	0.01 %
Linearity deviation	≤ 0.05 % full scale
Temperature drift	<= +- 0.003%/K
Ambient temperature	-25...+85 °C
Nominal distance	1.5 mm

#### Electrical data

Operating voltage	15...30 VDC
Ripple	≤ 10 % U <sub>ss</sub>
Rated insulation voltage	≤ 0.5 kV
Reverse polarity protection	yes (power supply)
Output function	IO-Link
Short-circuit protection	yes/cyclic
Sampling rate	1000 Hz
Current consumption	< 100 mA
Communication	IO-Link specified acc. to version 1.1
Parametrization	FDT / DTM
Transmission rate	COM 2 / 38.4 kbps
Frame type	2.2

#### Housing

Dimensions	81 x 78 x 24 mm
Housing material	metal/plastic, ZnAlCu1/PBT-GF30-V0
Connection	male connector, M12 x 1, 5-pin
Vibration resistance	55 Hz (1 mm)
Vibration resistance (EN 60068-2-6)	20 g, 10...3000 Hz, 50 cycles, 3 axes
Shock resistance (EN 60068-2-27)	100 g, 11 ms ½ sine, each 3x, 3 axes
Continuous shock resistance (EN 60068-2-29)	40 g, 6 ms ½ sine, each 4000x, 3 axes
Protection class	IP68/IP69K
MTTF	138 years acc. to SN 29500 (Ed. 99) 40 °C

#### LED indication

Operating voltage	LED green
Display switching status	LED yellow
Measuring range	LED yellow, yellow flashing

# Incremental Encoder

## Product features



- Measuring range indicated via LED
- Immune to electromagnetic interference
- 1024 pulses per revolution (default)
- 360, 512, 1000, 1024, 2048, 2500, 3600, 4096, 5000 can be set via Easy Teach
- 1...5000 can be set via PACTware™
- Burst function, incremental output of angular position after connecting power.
- Max. output frequency: 200 kHz
- Output signal 10...30 VDC push-pull
- Male connector, M12 x 1, 8-pin
- Outputs A, B,  $\bar{A}$ ,  $\bar{B}$ , Z

## LED indication



- green: Sensor power supply OK
- yellow off: Positioning element in measuring range
- yellow on: Positioning element has reached the end of the measuring range. This is indicated by a weaker signal.
- yellow flashing: Positioning element is outside the coverage

**Ri 360 P1 – QR24 M1 – INCR X2 – H1 1 8 1**

Ri 360 P1	Functional principle	– QR24 M1	Design	– INCR X2	Electrical version
	<ul style="list-style-type: none"> <li>Positioning element/for shaft diameter</li> <li>P0 without positioning element</li> <li>P1 P1-Ri-QR24/20 mm*</li> <li>P2 P2-Ri-QR24/14 mm*</li> <li>P3 P3-Ri-QR24/12 mm*</li> <li>P4 P4-Ri-QR24/10 mm*</li> <li>P5 P5-Ri-QR24/6 mm*</li> <li>P6 P6-Ri-QR24 / 3/8**</li> <li>P7 P7-Ri-QR24 / 1/4**</li> <li>P8 P8-Ri-QR24 / -</li> </ul>		<ul style="list-style-type: none"> <li>Mounting aid</li> <li>M0 without aluminum ring</li> <li>M1 with aluminum ring</li> <li>M2 Set M2-QR24 (M1-QR24 + SP1-QR24)</li> <li>M3 Set M3-QR24 (M1-QR24 + SP2-QR24)</li> <li>M4 Set M4-QR24 (M1-QR24 + SP3-QR24)</li> </ul>		<ul style="list-style-type: none"> <li>Number of LEDs</li> <li>X2 2x LED</li> </ul>
	<ul style="list-style-type: none"> <li>Measuring range</li> <li>360 360°</li> </ul>		<ul style="list-style-type: none"> <li>Design</li> <li>QR24</li> </ul>		<ul style="list-style-type: none"> <li>Inter face</li> <li>INCRpush-pull A, B, <math>\bar{A}</math>, <math>\bar{B}</math>, Z</li> </ul>
	<ul style="list-style-type: none"> <li>Functional principle</li> <li>Ri rotary inductive</li> </ul>				

\* Positioning element with hollow shaft

**H11 8 1 Electrical connection**

- Assignment
- 1 standard assignment
- Number of contacts
- 8 8-pin M12 x 1
- Connector type
- 1 straight
- Connector type
- H1male M12 x 1

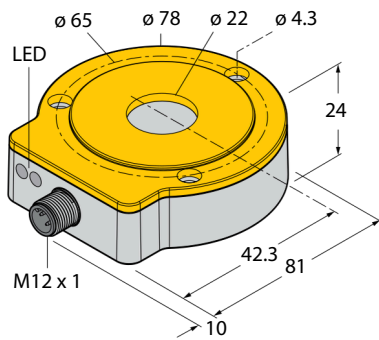

#### Wiring diagram

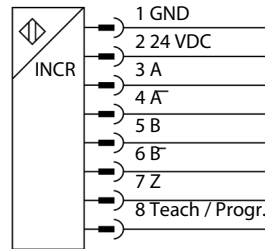

#### Pinout



#### max. rotational speed

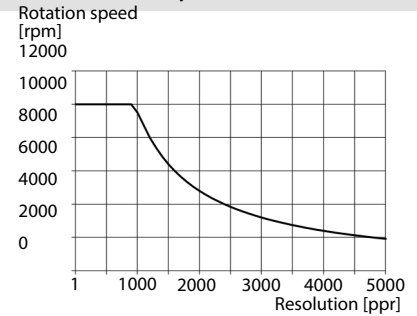

#### Measuring range details

Measuring range	0...360°
max. rotational speed	single turn mode 10.000 U/min determined with standardized construction, with a steel shaft Ø 20 mm, L = 50 mm and reducer Ø 20 mm
starting torque, shaft load	does not apply, because of contactless measuring principle

#### System

Resolution, incremental	1024 (default)
Repeatability	0.05 %
Linearity deviation	≤ 0.05 % full scale
Temperature drift	≤ ± 0.003 %/K
Ambient temperature	-25...+85 °C

#### Electrical data

Operating voltage	10...30 VDC
Ripple	≤ 10 % U <sub>ss</sub>
Rated insulation voltage	≤ 0.5 kV
Reverse polarity protection	yes (power supply)
Output function	push-pull/HTL
Pulse frequency max.	200 kHz
Signal level high	min. U <sub>b</sub> -2 V
Signal level low	max. 2.0 V
Sampling rate	1000 Hz
Current consumption	< 100 mA

#### Housing

Dimensions	81 x 78 x 24 mm
Housing material	metal/plastic, ZnAlCu1/PBT-GF30-V0
Connection	male connector, M12 x 1, 8-pin
Vibration resistance	55 Hz (1 mm)
Vibration resistance (EN 60068-2-6)	20 g, 10...3000 Hz, 50 cycles, 3 axes
Shock resistance (EN 60068-2-27)	100 g, 11 ms ½ sine, each 3x, 3 axes
Continuous shock resistance (EN 60068-2-29)	40 g, 6 ms ½ sine, each 4000x, 3 axes
Protection class	IP68/IP69K
MTTF	138 years acc. to SN 29500 (Ed. 99) 40 °C

#### LED indication

Operating voltage	LED green
Measuring range	LED yellow, yellow flashing

# Encoder Ri-QR24

## Absolutesingleturnencoderwith CANopen interface

### Product features

- ■ ■ ■ ■ ■ ■ ■ ■ ■
- CANopen interface
  - Baud rate 10 kbps up to 1 Mbps;
  - Factory setting: 125 kbps
  - Node address 1 to 127; Factory setting 3
  - Terminating resistor switched in via CANopen device access
  - 10...30 VDC
  - M12 x 1 male, 5-pin, CAN in, CAN out
  - Acc. to CiA DS-301, CiA 305, CiA 406

### LED indication

- Green:
  - Sensor is properly supplied, positioning element in the coverage
- Yellow:
  - Positioning element is in the measuring range, signal low (e.g. distance too large)
- Yellow flashing:
  - Positioning element is outside the coverage

### Status CAN

- Green/Red:
  - CAN communication active/not active
- Red/Green alternating:
  - LSS services active
- Green flashing:
  - Pre-operational state
- Green 1 x flashing:
  - CAN communication stopped
- Red 2 x flashing:
  - Error control event
- Red 3 x flashing:
  - Sync Error

**Ri360P0-QR24M1-CN X4-2H1150**

Ri 360 P0	Functional principle	- QR24 M1	Design	- CN	X4	Electrical version	-
	<ul style="list-style-type: none"> <li>Positioning element/for shaft diameter               <ul style="list-style-type: none"> <li>P0 without positioning element</li> <li>P1 P1-Ri-QR24/20 mm*</li> <li>P2 P2-Ri-QR24/14 mm*</li> <li>P3 P3-Ri-QR24/12 mm*</li> <li>P4 P4-Ri-QR24/10 mm*</li> <li>P5 P5-Ri-QR24/6 mm*</li> <li>P6 P6-Ri-QR24 / 3/8"*</li> <li>P7 P7-Ri-QR24 / 1/4"*</li> <li>P8 P8-Ri-QR24 / -</li> </ul> </li> <li>Measuring range               <ul style="list-style-type: none"> <li>360 360°</li> </ul> </li> <li>Functional principle               <ul style="list-style-type: none"> <li>Ri rotary inductive</li> </ul> </li> </ul>		<ul style="list-style-type: none"> <li>Mounting aid               <ul style="list-style-type: none"> <li>M0 without aluminum ring</li> <li>M1 with aluminum ring</li> <li>M2 Set M2-QR24 (M1-QR24 + SP1-QR24)</li> <li>M3 Set M3-QR24 (M1-QR24 + SP2-QR24)</li> <li>M4 Set M4-QR24 (M1-QR24 + SP3-QR24)</li> </ul> </li> <li>Design               <ul style="list-style-type: none"> <li>QR24</li> </ul> </li> </ul>			<ul style="list-style-type: none"> <li>Number of LEDs               <ul style="list-style-type: none"> <li>X4 4 x LEDs</li> </ul> </li> <li>Inter face               <ul style="list-style-type: none"> <li>CN CANopen</li> </ul> </li> </ul>	

\* Positioning element with hollow shaft

2H11	5	0	Electrical connection
			<ul style="list-style-type: none"> <li>Assignment               <ul style="list-style-type: none"> <li>0 standard assignment</li> </ul> </li> <li>Number of contacts               <ul style="list-style-type: none"> <li>5 5-pin M12 x 1</li> </ul> </li> <li>Connector type               <ul style="list-style-type: none"> <li>1 straight</li> </ul> </li> <li>Connector type               <ul style="list-style-type: none"> <li>H1male M12 x 1</li> </ul> </li> <li>Number of connectors               <ul style="list-style-type: none"> <li>2 2 x connectors</li> </ul> </li> </ul>

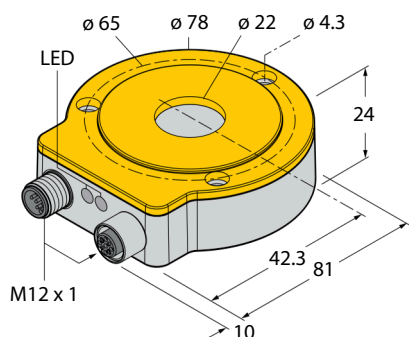

#### Pinout

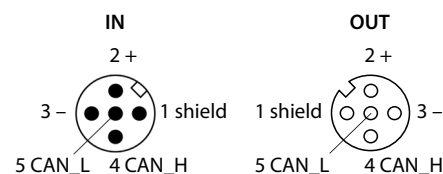

#### Measuring range details

Measuring range	0...360°
max. rotational speed	2.000 U/min determined with standardized construction, with a steel shaft Ø 20 mm, L = 50 mm and reducer Ø 20 mm
starting torque, shaft load	does not apply, because of contactless measuring principle

#### System

Resolution	16-bit
Repeatability	0.01 %
Linearity deviation	≤ 0.05 % full scale
Temperature drift	<= +- 0.003%/K
Ambient temperature	-25...+85 °C
Nominal distance	1.5 mm

#### Electrical data

Operating voltage	10...30 VDC
Ripple	≤ 10 % U <sub>ss</sub>
Rated insulation voltage	≤ 0.5 kV
Reverse polarity protection	yes (power supply)
Interface	CANopen, Profile DS406 V3.2, LSS DS 305
Node ID	1...127; factory setting: 3
Baud rate	10/20/50/125/250/500/1000 Kbit/s, factory setting 125 Kbit/s
Sampling rate	800 Hz
Current consumption	< 60 mA

#### Housing

Dimensions	81 x 78 x 24 mm
Housing material	metal/plastic, ZnAlCu1/PBT-GF30-V0
Connection	male connector, M12 x 1, 8-pin
Vibration resistance	55 Hz (1 mm)
Vibration resistance (EN 60068-2-6)	20 g, 10...3000 Hz, 50 cycles, 3 axes
Shock resistance (EN 60068-2-27)	100 g, 11ms ½ sine, each 3 x, 3 axes
Continuous shock resistance (EN 60068-2-29)	40 g, 6 ms ½ sine, each 4000 x, 3 axes
Protection class	IP68/IP69K
MTTF	138 years acc. to SN 29500 (Ed. 99) 40 °C

#### LED indication

Operating voltage	LED green
Status CANopen	green/red
Measuring range	LED, yellow, yellow flashing

# Stainless Steel Encoder EQR24 for the Harshest Environments

Turck offers a robust stainless steel variant of the QR24 contactless inductive encoder series. In the new EQR24 design the wear-free encoder is suitable for use in the food industry as well as in many other applications.

With a V4A stainless steel housing (1.4404) and an active face made from PA12-GF30 plastic the device can withstand even the harshest chemicals and pressures in the cleaning process.

As with all QR24 models, the sensor and positioning element are fully potted and cast as two totally sealed independent units that can withstand any vibration or shocks of the shaft. Wear-intensive ball bearings or seals which lead to machine downtimes and thus long maintenance times are not required.

Thanks to its intelligent mounting concept using adapter rings, the permanently sealed IP69K encoder can be fitted on all standard shafts with diameters up to 20 millimeters. Turck offers the stainless steel EQ24 variants with either an SSI or incremental output.



## Benefits

- Permanently wear-free through contact-less measuring principle
- No maintenance intervals required as the device can tolerate vibration and shaft misalignment
- Versatile mounting possibilities
- Reliable process operation in harsh and aggressive environments

## Product highlights

- Robust and fully sealed housing in IP67/IP69K
- Active face made from plastic (PA12-GF30) resistant to cleaning agents
- Stainless steel housing V4A (1.4404)
- Status indication via LED
- Easy Teach operation for rapid parameter setting, also at the device
- PACTware™ parameterization; for perfect adaption of encoders to the application
- Male connector, M12 x 1, 8-pin



# Encoder Ri-EQR24

## Absolute single / multiturn encoder with SSI interface with stainless steel housing

### Product features

- Compact and robust housing
- Active face from PA12-GF30 plastic
- Stainless steel housing V4A (1.4404)
- Status indication via LED
- SSI output
- 25-bit, gray coded
- SSI clock rate: 62.5 KHz ... 1 MHz
- Single or multiturn operation, data frame length as well as bit coding settable via PACTware with USB-2-IOL-0002 programming box and RKC8.302T-1,5-RSC4T/TX320 adapter cable
- Default setting: Single turn Bit 0 ... Bit 15, Multiturn Bit 16 ... Bit 21, Status Bit 22 ... Bit 24
- Zero point, synchronous/asynchronous operation and direction adjustable via Easy Teach
- Compatible with all standard SSI master devices
- In synchronous operation jitter < 5 µs
- No pull-up required on the master
- Immune to electromagnetic interference
- 15...30 VDC
- Male connector, M12 x 1, 8-pin
- yellow: Positioning element in measuring range with reduced signal quality (e.g. distance too large, see status bit 23)
- yellow flashing: Positioning element not in sensing range, see status bit 24

### LED indication

- green: Sensor power supply OK
- green flashing: Sensor in synchronous operation
- green fast flashing: Sensor power supply OK but not receiving CLK pulses of the SSI master
- yellow off: Positioning element in measuring range

### Multiturn faults

- red: Position changed during a power loss, see status bit 22

**Ri360P1-EQR24M1-HESG25X3-H1181**

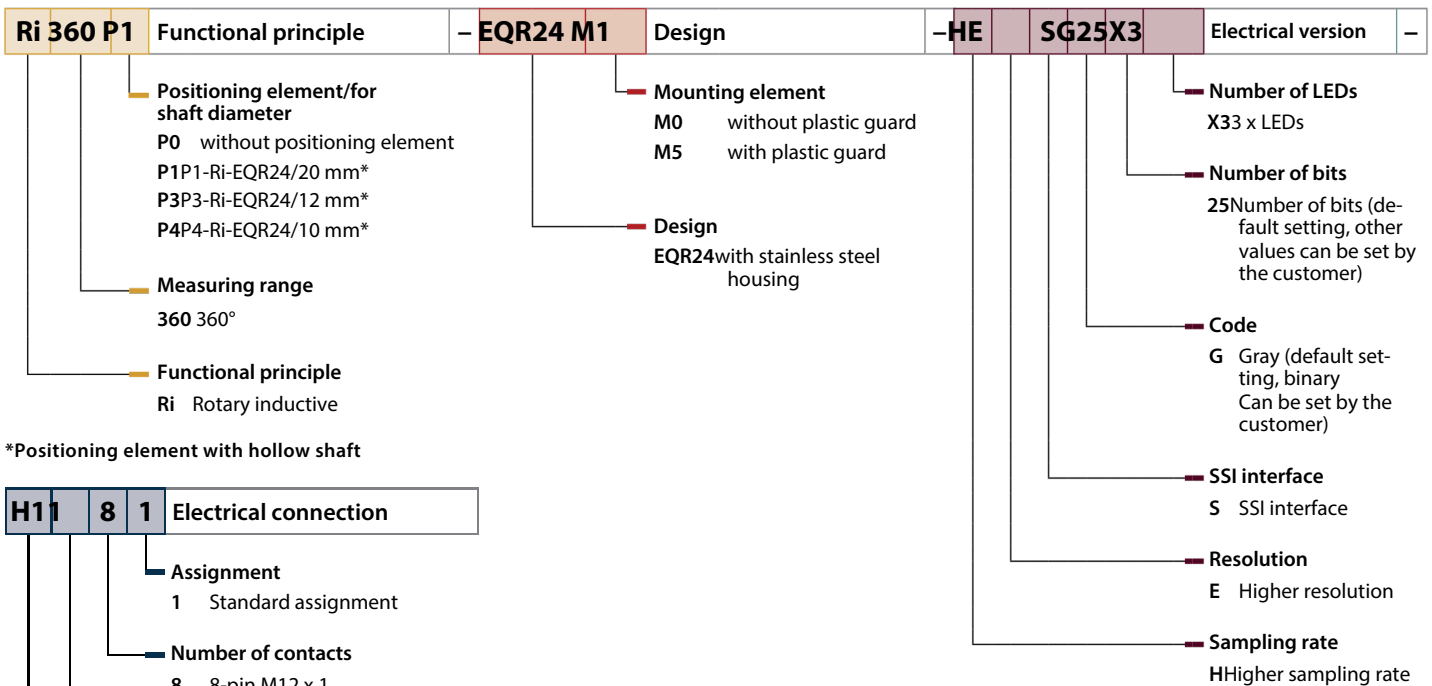

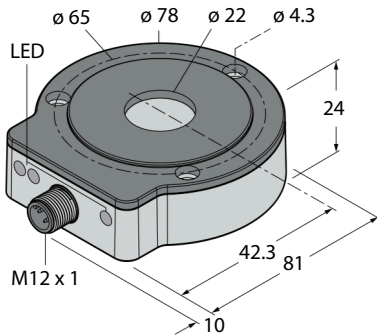

Wiring diagram

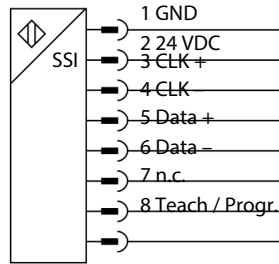

Connector view



### Measuring range information

Measuring range	0...360°
max. speed	6,000 (default) rpm Calculated in a standard setup with a steel shaft Ø 20 mm, L = 50 mm and reducing bushing Ø 20 mm
Starting torque, shaft load	Not applicable with contactless measuring principle

### System

Resolution single turn	16 bit 6 bit ≤ 0.01
Resolution multiturn	% full scale ≤ 0.05
Repetition accuracy	% full scale ≤ ±
Linearity tolerance	0.003 % / K -25...
Temperature drift	+85 °C
Ambient temperature	

### Electrical data

Operating voltage	15...30VDC
Ripple	≤ 10 % U <sub>ss</sub>
Rated insulation voltage	≤ 0.5 kV
Output function	8-pin, SSI, 25-bit, gray coded
Sampling rate	5000 Hz
Current consumption	the sampling rate of the sensor depends on the SSI cycle time of the master. It is 1 to 5 KHz (signal run time 200µs) in synchronized operation.
Housing	< 100 mA

### Dimensions

Housing material	81 x 78 x 24 mm
Connection	Stainless steel/plastic
Vibration resistance	connector, M12 x 1, 8-pin
Vibration resistance (EN 60068-2-6)	55 Hz (1 mm)
Shock resistance (EN 60068-2-27)	20 g, 10...3000 Hz, 50 cycles, 3 axes
Continuous shock resistance (EN 60068-2-29)	100 g, 11 ms ½ sine; each 3x, 3 axes
Degree of protection	40 g, 6 ms ½ sine, each 4000x, 3 axes
MTTF	IP68/IP69K
LEDs	138 years according to SN 29500 (Ed. 99) 40 °C

### Operating voltage indication

Measuring range indication	LED green
Fault indication	LED yellow, yellow flashing
	LED red

# Encoder Ri-EQR24

Push pull with A, B,  $\bar{A}$ ,  $\bar{B}$  and Z track with stainless steel housing

## Product features

- Compact and robust housing
- Active face plastic PA12-GF30
- Stainless steel housing V4A (1.4404)
- Status indication via LED
- Immune to electromagnetic interference
- 1024 pulses per revolution (factory setting)
- 360, 512, 1000, 1024, 2048, 2500, 3600, 4096, 5000 can be set via Easy Teach
- Free parameterization of pulse number between 1 and 5,000 via PACTware
- Position of the Z track settable via Easy Teach
- Burst function, incremental output of the absolute angle position via Easy Teach pulse
- 10...30 VDC
- Male connector, M12 x 1, 8-pin
- Push pull A, B, Z,  $\bar{A}$  (inverse),  $\bar{B}$  (inverse)

## LED indication

- green: Sensor power supply OK
- yellow off: Positioning element in measuring range
- yellow: Positioning element is in the measuring range, reduced signal quality (e.g. distance too large)
- yellow flashing: Positioning element is not in the measuring range

**Ri 360 P1 – EQR24 M1 – INCR X2 – H1 1 8 1**

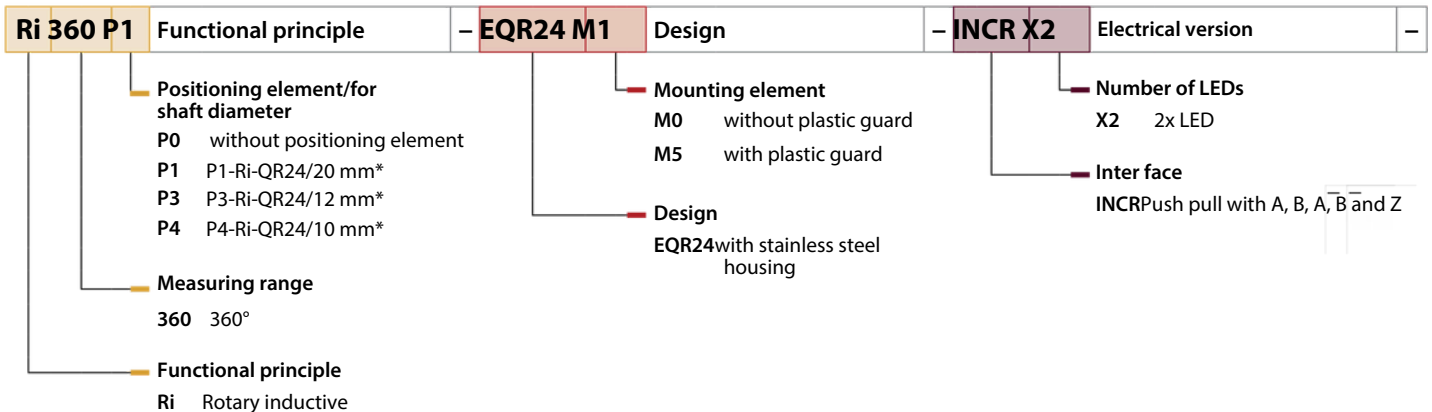

\*Positioning element with hollow shaft

**H11 8 1 Electrical connection**

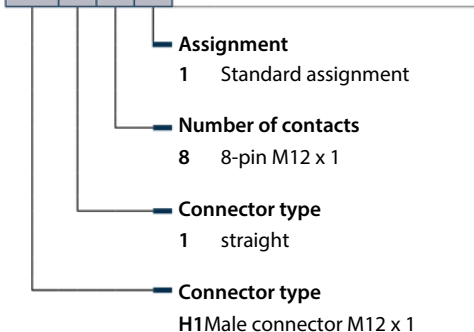

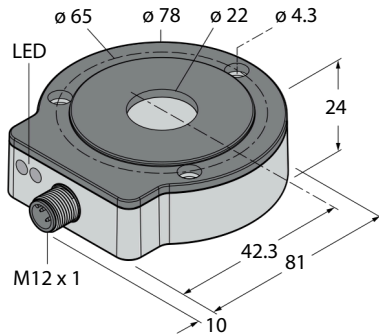

#### Wiring diagram

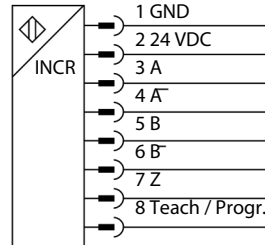

#### Pinout



#### max. rotational speed

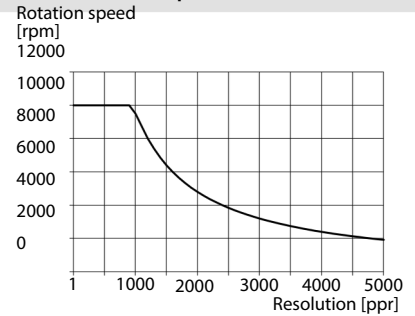

#### Measuring range details

Measuring range	0...360°
max. rotational speed	single turn mode 10.000 U/min determined with standardized construction, with a steel shaft $\varnothing$ 20 mm, L = 50 mm and reducer $\varnothing$ 20 mm
starting torque, shaft load	does not apply, because of contactless measuring principle

#### System

Resolution, incremental	1024 (default)
Repeatability	0.05 %
Linearity deviation	$\leq 0.05$ % full scale
Temperature drift	$\leq \pm 0.003$ %/K
Ambient temperature	-25...+85 °C

#### Electrical data

Operating voltage	10...30 VDC
Ripple	$\leq 10$ % $U_{ss}$
Rated insulation voltage	$\leq 0.5$ kV
Reverse polarity protection	yes (power supply)
Output function	push-pull/HTL
Pulse frequency max.	200 kHz
Signal level high	min. $U_b$ -2 V
Signal level low	max. 2.0 V
Sampling rate	1000 Hz
Current consumption	< 100 mA

#### Housing

Dimensions	81 x 78 x 24 mm
Housing material	metal/plastic, ZnAlCu1/PBT-GF30-V0
Connection	male connector, M12 x 1, 8-pin
Vibration resistance	55 Hz (1 mm)
Vibration resistance (EN 60068-2-6)	20 g, 10...3000 Hz, 50 cycles, 3 axes
Shock resistance (EN 60068-2-27)	100 g, 11 ms $\frac{1}{2}$ sine, each 3x, 3 axes
Continuous shock resistance (EN 60068-2-29)	40 g, 6 ms $\frac{1}{2}$ sine, each 4000x, 3 axes
Protection class	IP68/IP69K
MTTF	138 years acc. to SN 29500 (Ed. 99) 40 °C

#### LED indication

Operating voltage	LED green
Measuring range	LED yellow, yellow flashing

# Accessories for Fieldbus Connections

The version with the SS interface is suitable as an encoder for all fieldbus devices

The encoders are often required to be connected directly to the fieldbus that communicates with the higher-level controller. This enables the position feedback signals of the sensor to be transferred directly to the fieldbus system (e.g. to PROFIBUS-DP, DeviceNet™, CAN-open or to Ethernet-based protocols) – this consequently eliminates the need for analog input modules.

In order to offer maximum flexibility for connecting sensors, Turck also provides modular solutions, i.e. linear position sensor, extension cable and fieldbus modules are available as separate components. The Turck sensors are therefore considerably more compact than the large sensors with integrated fieldbus connection. This eliminates any space problems right from the start.

Turck supplies fieldbus modules as remote I/O systems both in IP20 for the control cabinet (BL20) as well as in IP67 for harsh ambient conditions (BL67). The devices can be programmed with CODESYS (IEC 61131) for signal preprocessing or also for stand-alone solutions (for relieving the load on the bus and higher-level controller). If the remote I/O systems are too large, Turck's exceptionally space saving piconet® fieldbus system and BLcompact systems offer the optimum solution – with highly rugged modules for direct field installation.

- All standard fieldbus systems
- Very simple changing between fieldbus system
- Modular principle
- High flexibility
- Sensor independent of fieldbus system
- Exceptionally space saving





Designation	Description
<b>piconet® – IP67 protection – Exceptionally compact</b>	
SDPB-10S-0005	PROFIBUS-DP, M23, 12-pin
SDNB-10S-0005	DeviceNet™, M23, 12-pin
SCOB-10S-0005	CANopen, M23, 12-pin
E-RKS8T-264-1-CSWM12/S3085	M12 extension cable, 8-pin, to M23, 12-pin, 1 m for connecting encoders with SSI output to BL67 and <i>piconet</i> ® fieldbus stations
<b>BL67 – Remote I/O system with protection to IP67</b>	
BL67-GW-DPV1	PROFIBUS-DP gateway
BL67-PG-DP	Gateway PROFIBUS-DP, programmable
BL67-GW-DN	DeviceNet™ gateway
BL67-GW-CO	CANopen gateway
BL67-GW-EN	Gateway Ethernet multiprotocol
BL67-PG-EN	Gateway Ethernet Modbus TCP, programmable
BL67-1SSI	Communication module
BL67-B-1M12-8	Connection module M12, 8-pin
BL67-B-1M23	Connection module M12, 12-pin
RKS8.703T-2-RSS8.703T/TXL	M12 extension cable, 8-pin
<b>BL20 – Remote I/O system with protection to IP20</b>	
BL20 GW DPV1	PROFIBUS-DP gateway
BL20-GWBR-DNET	DeviceNet™ gateway
BL20-GWBR-CANOPEN	CANopen gateway
BL20-E-GW-EN	Gateway Ethernet multiprotocol
BL20-PG-EN	Gateway Ethernet Modbus TCP, programmable
BL20-1SSI	Communication module
BL20-S4T-SBBS	Connection module, tension spring connection
E-RKC8T-264-2	M12 extension cable, 8-pin, 2 m open cable end for connecting encoders with SSI output to BL20 fieldbus stations

### BL20 example configuration

The following components are required to connect an encoder sensor to a Profibus system via a BL20 station:

1 x PROFIBUS gateway	1 x communication module	1 x connection module	1 x connection cable
BL20 GW DPV1	BL20-1SSI	BL20-S4T-SBBS	E-RKC-8T-264-2

### piconet® example configuration

The following components are required to connect an encoder sensor to a PROFIBUS system via a piconet® station:

1 x PROFIBUS compact station	1 x connection cable
SDPB-10S-0005	E-RKS-8T-264-1-CSWM12/S3085





# Accessories

## Connection accessories

Adapter cable	Type	Description
	RKC8.302T-1,5-RSC4T/TX320	Adapter cable for connecting the SSI/incremental sensor to the parameter unit USB-2-IOL-0002, PUR
Connection cable for series with analog output	Type	Description
	RKS4.5T-2/TXL	Connection cable M12, 5-pin, shielded, 2 m with open end, PUR
Connection cable for series with SSI/incremental interface	Type	Description
	E-RKC8T-264-2	M12 extension cable, 8-pin, 2 m open cable end for connecting encoders with SSI output to BL20 fieldbus stations
	E-RKS8T-264-1-CSWM12/S3085	M12 extension cable, 8-pin, to M23, 12-pin, 1 m for connecting encoders with SSI output to BL67 and piconet® fieldbus stations

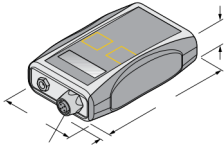
No matter the shaft diameter, we ensure maximum flexibility with our extensive range of accessories. Here you find the right mounting aid:

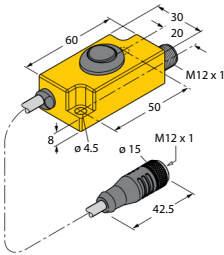
## Function accessories

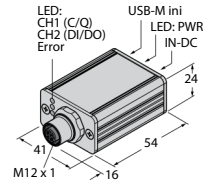
	Dimension drawing	Type	Description
		TB4	Analog test box; Test box for sensors with analog or switching SSI; incl. batteries
		TX1-Q20L60	Teach adapter for programming the measuring range of inductive encoders with a 5-pin male (analog)
		TX2-Q20L60	Teach adapter for programming the measuring range of inductive encoders with an 8-pin male (incremental and SSI )
		USB-2-IOL-0002	IO-Link master with integrated USB interface for parametrizing the IO-Link-capable encoders via a PC

## Ready-to-install positioning elements

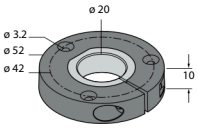
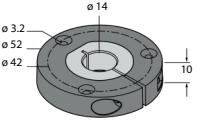
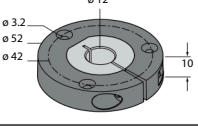
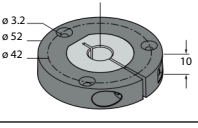
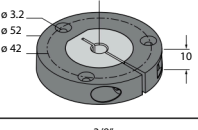
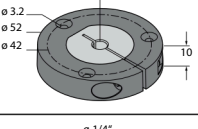
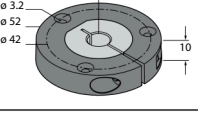
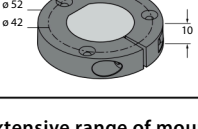

Dimension drawing	Type	Description
	P1-Ri-QR24	Positioning element with hollow shaft 20 mm
	P2-Ri-QR24	Positioning element with hollow shaft 14 mm
	P3-Ri-QR24	Positioning element with hollow shaft 12 mm
	P4-Ri-QR24	Positioning element with hollow shaft 10 mm
	P5-Ri-QR24	Positioning element with hollow shaft 6 mm
	P6-Ri-QR24	Positioning element with hollow shaft 3/8"
	P7-Ri-QR24	Positioning element with hollow shaft 1/4"
	P8-Ri-QR24	Positioning element with blanking plug

Extensive range of mounting accessories for easy adaptation to many different shaft diameters.

More on request!

# Accessories

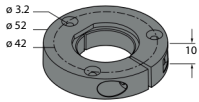
## Positioning elements and reducing bushings

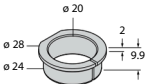
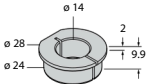
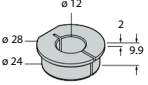
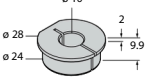
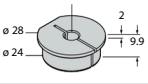
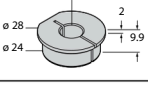
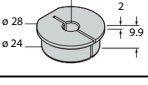
Dimension drawing	Type	Description
	PE1-QR24	Base unit for positioning element
	RA8-QR24	Blanking plug
	RA1-QR24	Reducing bushing 20 mm
	RA2-QR24	Reducing bushing 14 mm
	RA3-QR24	Reducing bushing 12 mm
	RA4-QR24	Reducing bushing 10 mm
	RA5-QR24	Reducing bushing 6 mm
	RA6-QR24	Reducing bushing 3/8"
	RA7-QR24	Reducing bushing 1/4"

The positioning element and the different reducing bushings can of course be ordered separately. The modular principle ensures easy storage and flexibility.

More on request!

## Positioning elements and reducing bushings for EQR24

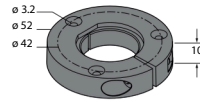
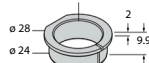
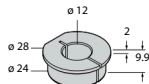
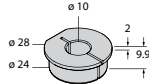
Dimension drawing	Type	Description
	PE1-EQR24	Positioning element with stainless steel terminal gland, without reducing bushing
	RA1-EQR24	Stainless steel reducing bushing to connect to Ø 20 mm shafts
	RA3-EQR24	Stainless steel reducing bushing to connect to Ø 12 mm shafts
	RA4-EQR24	Stainless steel reducing bushing to connect to Ø 10 mm shafts

The accessories (Type: MT-QR24) enclosed in the delivery help to mount encoder and positioning element at an optimal distance from each other. In addition, LEDs indicate the switching status. The shields listed in the chapter "Accessories" can optionally be used to increase the allowed distance between positioning element and sensor.

### Standard accessories

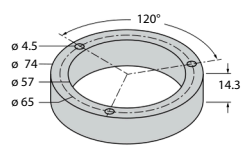
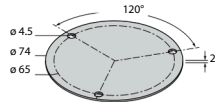
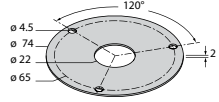
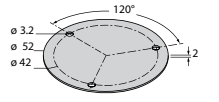
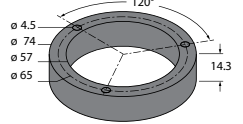
Dimension drawing	Type	Description
	M1-QR24	Aluminum ring
	M2-QR24	M1-QR24+SP1-QR24
	M3-QR24	M1-QR24+SP2-QR24
	M4-QR24	M1-QR24+SP3-QR24
	M5-QR24	Plastic protection ring for Ri-EQR24 inductive encoders

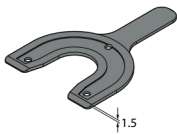
Dimension drawing	Type	Description
	MT-QR24	Mounting aid, already included in the delivery scope of the encoder

### Shield

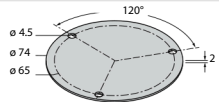
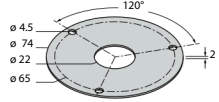
Dimension drawing	Type	Description
	SP1-QR24	Shield Ø 74 mm, aluminum
	SP2-QR24	Shield Ø 74 mm with bore for shaft guidance, aluminum

## Mounting Options

You can easily adapt the sensor to many different shaft diameters with the extensive range of mounting accessories. Based on the functional principle of RLC coupling, the sensor operates absolutely wear-free and is immune to magnetized metal splinters and other interference fields. Wrong installation is hardly possible.

The separately arranged sensor and positioning element inhibit that compensating currents or damaging mechanical loads are transmitted via the shaft to the sensor. In addition, the encoder remains tight and highly protected during its entire lifespan.

The figure below shows the two separate units, sensor and positioning element.



**Mounting option A:**

First, interconnect the positioning element and the rotatable shaft. Then place the encoder above the rotating part in such a way that you get a tight and protected unit.

**Mounting option B:**

Push the encoder on the back site of the shaft and fasten it to the machine. Then clamp the positioning element to the shaft with the bracket.



**Mounting option C:** If the positioning element is to be screwed on a rotating machine part and not on a shaft, first insert the RA8-QR24 blanking plug. Then tie up the bracket. Screw on the encoder via the three bores.

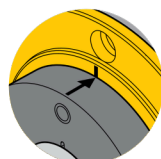
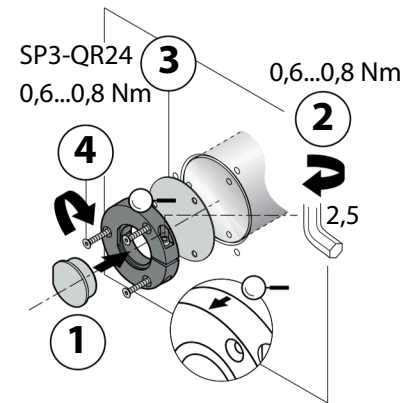
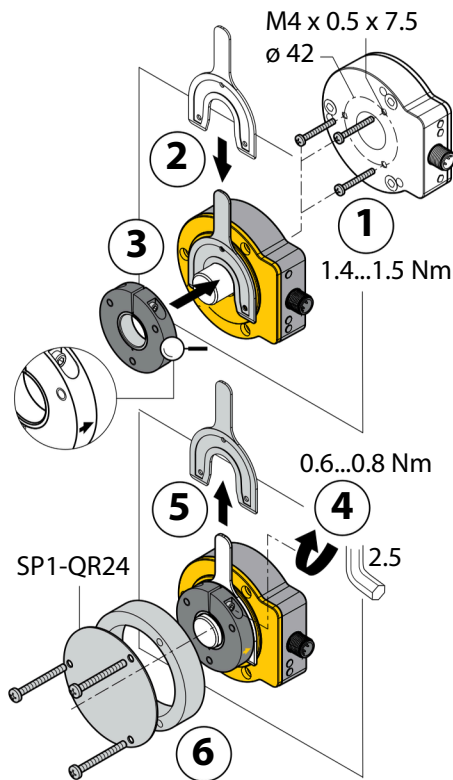
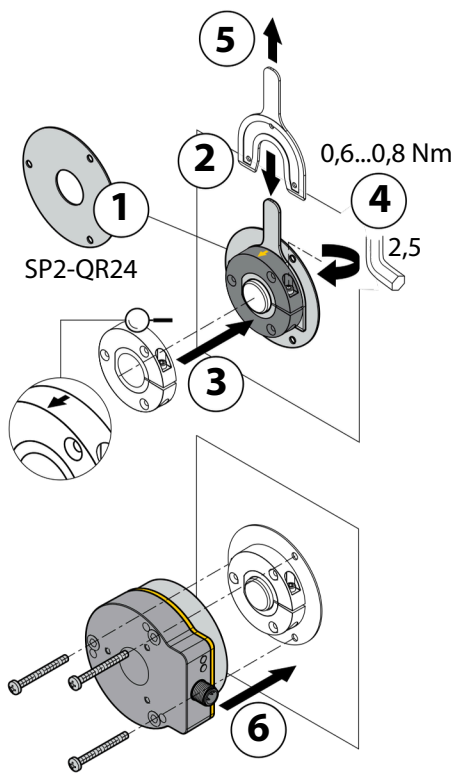



**Address:-** Sector 130, Shastri Garhi Shahpur, Noida,  
Uttar Pradesh- 201304

**Mob:-** +91 - 981187005, 9711966037, 9711966066

**Email:-** seereba@seereba.com, sales@seereba.com

**Website:-** www.seereba.com

# TURCK

A light gray silhouette of a world map is positioned in the bottom third of the page, serving as a background for the text.

28 subsidiaries and over  
60 representations worldwide!

D101999 | 2015/11

**\*D101999BB1511\***

[www.turck.com](http://www.turck.com)